



ADAPT
COMMERCIAL STRING LIGHT

ADAPT COMMERCIAL STRING LIGHT- How it works

Choose your cord color, light engine, and multiple globe options to create a unique experience for any personal or public space

Choose Your Cord: →

Tivoli's standard 48' strand with (24) E26 Medium base sockets. Available in black or white with 24" O.C. socket spacing.

Order Your Light Engine: →

4W each with a lumen delivery up to 400 lumens per light engine. Available in 2700K and 3000K only.

Multiple ADAPT Globes: →

Available in both G125 and ST19 profiles. Total of 11 styles to choose from.





Order Information - String and Light Engine



COMMERCIAL STRING
TCSL-S-X-24-120
X = B (black), W (white)
 48' Commercial string/cord, 24" O.C.
 with molded male and female end



ALS-TF-T25-E26-4W-XXK-6PK-R
XXK = 27K (2700K), 30K (3000K)
 Filament Light Engine
 Sold as 6 Pack with (1) rubber O-Ring per Bulb

Specification

ADAPT Commercial String Light (based on 2700K)	
Socket Spacing	24"
Socket Type	E26
Socket Count	24
Cord Length	48' with male and female molded ends
Cord Type	3C x 14AWG SJTW
Cord Plug	5-15P Polarized
Cord Weight	7.85 lbs.
Available Cord Color	Black, White
Field Cuttable Cord	NO
Operating Voltage	120V AC
Watts/Strand	96W based on 10% voltage drop
Max Run	Feet (384), Strand sets (8), Watts (768)
ADAPT Globe	
Globe	Glass (Shatter resistance assist with silicone coating - Glass may still break under certain conditions)
ADAPT Light Engine	
Watts/bulb	4W
Lumens/bulb	400 light engine only (Lumen output may vary based on globe choice)
Weight (lbs)/bulb	.10
Kelvin Temperature	2700K, 3000K
CRI	80+
Operating Voltage	120V AC
Dimming	ELV, TRIAC
Base	E26 Medium base
Certification and Testing	
Certification (Cord, Light Engine)	cETLus
Environment (Cord, Light Engine)	Wet Location
IP Rating (Cord, Light Engine)	IP65
Lifetime Hours (Light Engine)	15,000
Warranty (Cord, Light Engine)	3 Years

Order Information - ADAPT Globe

G125 Globe (Weight: .25 lbs/ea.)



(Shatter resistance assist with silicone coating - Glass may still break under certain conditions)



Ana
LSA-ANA-N



Angela
LSA-ANG-N



Gina
LSA-GIN-N



Gaby
LSA-GAB-N



Katie
LSA-KAT-N



Susan*
LSA-SUS-N



Toni*
LSA-TON-N



Lucia*
LSA-LUC-N



Victoria*
LSA-VIC-N

ST19 Globe (Weight: .10 lbs/ea.)



Brenda
LSA-BRE-N



Shatter Resistant
Silicone Coating



Laura*
LSA-LAU-N

*Consult Factory for MOQ and Lead Time.

Standard Spacing and Weights

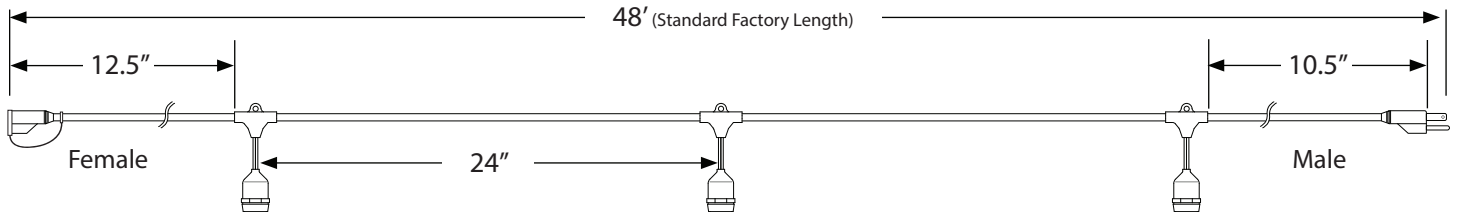

Filament light engine and ST19 total weight w/48 ft. string

12.65 lbs.

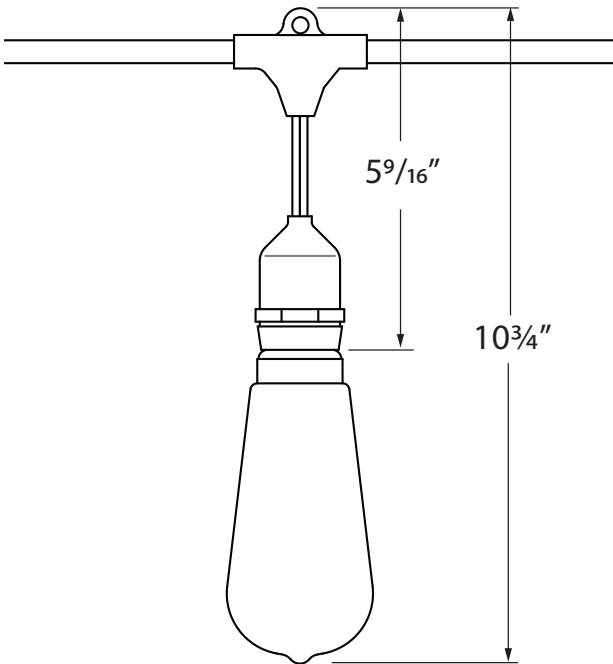

Filament light engine and G25 total weight w/48 ft. string

16.25 lbs.

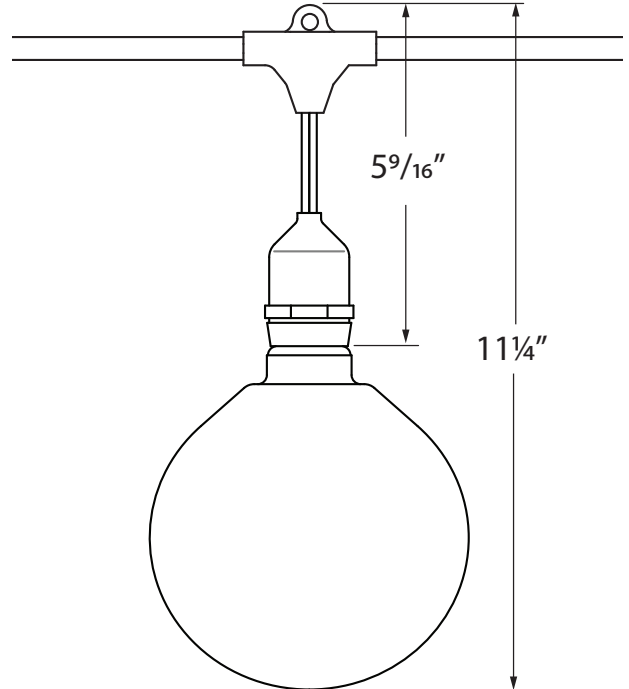

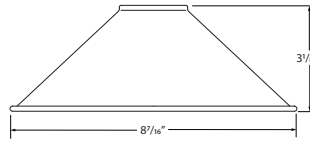
Light Shades
HAT

SHADE-HT-BK-BK-8
Light Shade - HAT
8.3" Black Top, Black Bottom

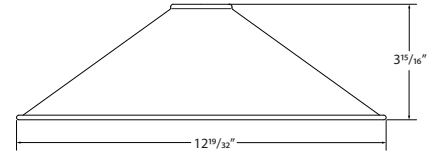

SHADE-HT-BK-BK-13
Light Shade - HAT
12.6" Black Top, Black Bottom
***SHADE-HT-BK-CO-13**
Light Shade - HAT
12.6" Black Top, Copper Bottom

*Consult factory for lead time and MOQ

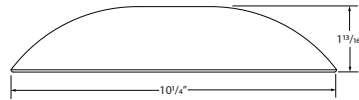
DISH

SHADE-DS-BK-BK-10
Light Shade - DISH
10.2" Black Top, Black Bottom

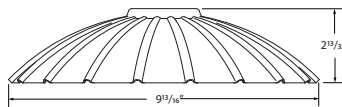
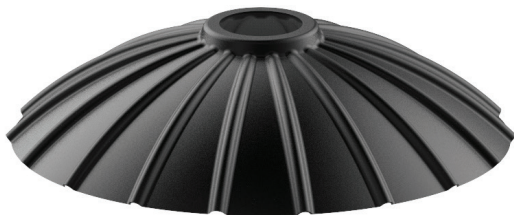
FLOWER

SHADE-FL-BK-BK-10
Light Shade - FLOWER
9.8" Light Shade, Black Top, Black Bottom

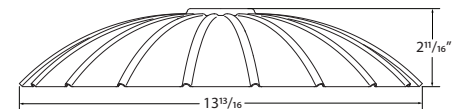

SHADE-FL-BK-BK-13
Light Shade - FLOWER
13.8" Light Shade, Black Top, Black Bottom

Accessories

SHADE-ADP-CSL-BK-25 Light Shade Adapter
PVC Black Adapters - Sold in packs of 25
Comes with (25) Adapters, (50) set screws and (1) Allen Key.

SHADE-ADP-CSL-BK-01 Light Shade Adapter
PVC Black Adapters - Sold individually
Comes with (1) Adapters, (2) set screws and (1) Allen Key.

*Consult factory for lead time and MOQ

Mounting

WARNING: For suspension application, catenary cable is required to support the product, otherwise the warranty will be void.



LS-CABLE-60 Catenary Cable Kit - 60'
 (1/8" stainless steel aircraft cable includes 2 cables locks for use with loads up to 200lbs)

LS-CABLE-110 Catenary Cable Kit - 110'
 (1/8" stainless steel aircraft cable includes 2 cables locks for use with loads up to 200lbs)

LS-CABLE-500 Catenary Cable Kit - 500'
 (1/8th" stainless steel aircraft cable for use with loads up to 200lbs)



LS-LOCK-X Cable Lock
 X = 2 (2 Locks), 4 (4 locks) Includes (1) cable release key.
 Cable Lock for 1/8th inch cable, Heavy-duty lockable fasteners support loads up to 200 lbs. Can be easily adjusted without the use of tools.



LS-TT Catenary Tensioning Tool
 Catenary Cable Tensioning Tool up to 880lbs with minimal effort due to the 6:1 gear drive mechanism. Integral torque gauge controls the load applied to the wire, giving consistent tension every time and optimizing the life of the wire.



LS-UVZP-BK-50 UV Zip Ties
 50 pc Bag set. UV resistant, heavy duty ties. Maximum weight up to 100 lbs./per tie.



LS-UVZP-BK-30 UV Zip Ties
 30 pc Bag set. UV resistant, heavy duty ties. Maximum weight up to 100 lbs./per tie.

Installation with Suspension Cable

